

Evaluate sail quality by looking closely at the details. Excellence is the hallmark of a Quantum® sail. Below are a few of the quality details that define a Quantum® sail and ensure long-lasting performance.

CUSTOM HEADBOARD

Custom aluminum headboard installation utilizes stainless steel pressed rings (as opposed to rivets) reinforced with webbing.

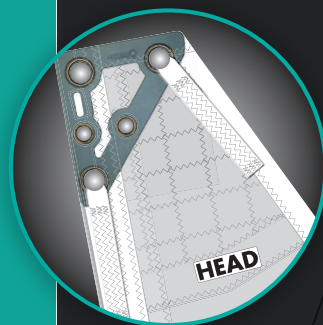

REEF DETAILS

Mainsail leech reef detail showing extensive, oversized reef patching, "quilted" stitching, stainless steel press rings reinforced with webbing, separate aluminum leech cord cleat hand stitched.

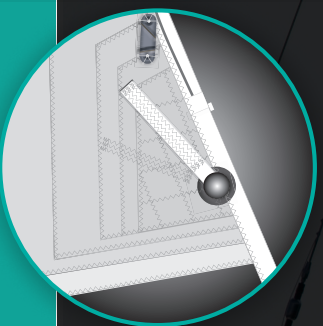

HAND FINISHING

Custom, webbed on stainless steel clew ring in oversized clew patch finished with three rows of hand stitching.

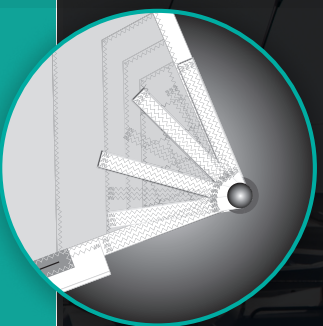

CORNER REINFORCEMENTS

Headsail head detail showing oversized corner reinforcement, glued and secured with "quilted" stitching, luff tape finishing, external leech cord terminus (simplifying repair or replacement), and webbing attachment for halyard.

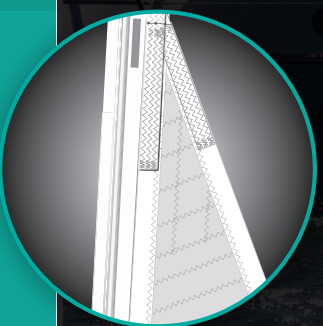

Quantum also offers membrane sails for cruising, which offer superior shape-holding and greater control. To learn more about Fusion M® sails contact your local loft or visit our website, www.QuantumSails.com.

PHOTO CREDITS: Photos courtesy of Passport Yachts
031212 ©2012 Quantum Sail Design Group, LLC. All rights reserved.

QUALITY IS IN THE DETAILS



WOVEN POLYESTER CRUISING SAILS



QUANTUM Greece
ilissou 227-229, Moschato, Athens, 183 45
Tel. +30 2109341815, Fax: +30.2109341676
www.quantumsails.gr | email: jtahtatzis@quantumsails.gr

QUANTUM Lefkas
Tel./Fax +30 26450 21461
email: waypointsails@yahoo.com

QUANTUM Corfu
Tel. +30 26610 90130
email: giatrassails@hotmail.com

